

DESCRIPTION

The RH1814 is a quad, low power, high speed, very high slew rate operational amplifier with excellent DC performance, reduced supply current, lower input offset voltage, lower input bias current and higher DC gain than other devices with comparable bandwidth. The circuit topology is a voltage feedback amplifier with the slewing characteristics of a current feedback amplifier.

The output drives a 100 Ω load to $\pm 3.35V$ with $\pm 5V$ supplies. On a single 5V supply, the output swings from 1.1V to 3.7V with a 100 Ω load connected to 2.5V. The amplifiers are stable with a 1000pF capacitive load making them useful in buffer and cable driver applications.

The RH1814 is manufactured on Linear Technology's advanced low voltage complementary bipolar process.

ABSOLUTE MAXIMUM RATINGS

(Note 1)

Supply Voltage	12.6V
Differential Input Voltage (Note 2)	$\pm 6V$
Input Voltage	$\pm V_S$
Output Short-Circuit Duration (Note 3)	Indefinite
Operating Temperature Range	$-55^{\circ}C$ to $125^{\circ}C$
Storage Temperature Range	$-65^{\circ}C$ to $150^{\circ}C$
Lead Temperature (Soldering, 10 sec)	$300^{\circ}C$

 LTC and LT are registered trademarks of Linear Technology Corporation.

BURN-IN CIRCUIT

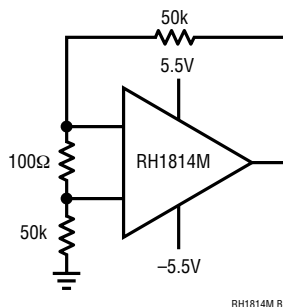

PACKAGE INFORMATION

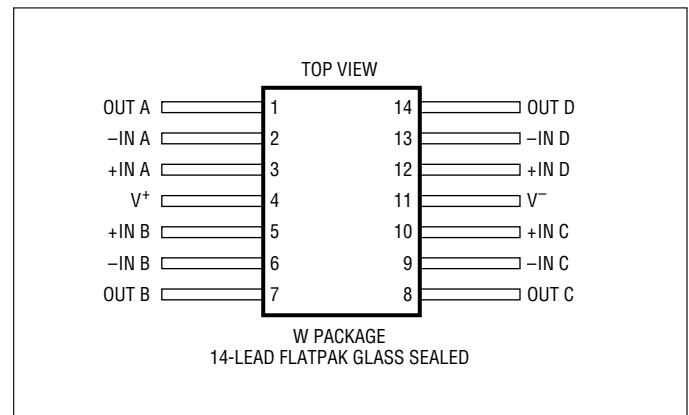

TABLE 1: ELECTRICAL CHARACTERISTICS (Pre-Irradiation) $V_S = \pm 5V$, $V_{CM} = 0V$, unless otherwise noted.

SYMBOL	PARAMETER	CONDITIONS	$T_A = 25^\circ C$			SUB-GROUP	$-55^\circ C \leq T_A \leq 125^\circ C$			SUB-GROUP	UNITS
			MIN	TYP	MAX		MIN	TYP	MAX		
V_{OS}	Input Offset Voltage	(Note 4)			1.5	1			4	2,3	mV
$\frac{\Delta V_{OS}}{\Delta Temp}$	Average Tempco of Offset Voltage	(Note 5)							30		$\mu V/^\circ C$
I_{OS}	Input Offset Current				400	1			1000	2,3	nA
I_B	Input Bias Current				± 4	1			± 10	2,3	μA
e_n	Input Noise Voltage Density	$f_0 = 10kHz$			8						nV/\sqrt{Hz}
i_n	Input Noise Current Density	$f_0 = 10kHz$			1						pA/\sqrt{Hz}
R_{IN}	Input Resistance	$V_{CM} = \pm 3.5V$			3						M Ω
A_{VOL}	Large-Signal Voltage Gain	$V_0 = \pm 3V$, $R_L \geq 500\Omega$			1.5	4		0.7		5,6	V/mV
		$V_0 = \pm 3V$, $R_L \geq 100\Omega$			1	4		0.5			V/mV
	Input Voltage Range	Guaranteed by CMRR			± 3.5			± 3.5			V
CMRR	Common-Mode Rejection Ratio	$V_{CM} = \pm 3.5V$			75	1		70			dB
PSRR	Power Supply Rejection Ratio	$V_S = \pm 2V$ to $\pm 5.5V$			78	1		72		2,3	dB
	Channel Separation	$V_0 = \pm 3V$, $R_L = 100\Omega$			82	1		78			dB
V_{OUT}	Output Voltage Swing	$R_L = 500\Omega$, 30mV Overdrive			± 3.8	4		± 3.4		5,6	V
		$R_L = 100\Omega$, 30mV Overdrive			± 3.35	4		± 3		5,6	V
I_{OUT}	Maximum Output Current	$V_{OUT} = \pm 3V$, 30mV Overdrive			± 40			± 20			mA
I_{SC}	Output Short-Circuit Current	$V_{OUT} = 0V$, 1V Overdrive (Note 3)			± 75			± 40			mA
I_S	Supply Current	Per Amplifier			3.6	1		6.5		2,3	mA

TABLE 2: ELECTRICAL CHARACTERISTICS (Post-Irradiation, Note 7) $V_S = \pm 5V$, $V_{CM} = 0V$, $T_A = 25^\circ C$, unless otherwise noted.

SYMBOL	PARAMETER	CONDITIONS	10KRAD(Si)		20KRAD(Si)		50KRAD(Si)		100KRAD(Si)		200KRAD(Si)		UNITS
			MIN	MAX	MIN	MAX	MIN	MAX	MIN	MAX	MIN	MAX	
V_{OS}	Input Offset Voltage	(Note 4)	2		2		2.5		3		4		mV
I_{OS}	Input Offset Current		500		500		750		1000		1500		nA
I_B	Input Bias Current		± 5		± 5		± 7.5		± 10		± 15		μA
	Input Voltage Range	Guaranteed by CMRR	± 3.5		± 3.5		± 3.5		± 3.5		± 3.5		V
CMRR	Common-Mode Rejection Ratio	$V_{CM} = \pm 3.5V$	73		73		71		68		65		dB
PSRR	Power Supply Rejection Ratio	$V_S = \pm 2V$ to $\pm 5.5V$	77		75		72		70		68		dB
A_{VOL}	Large-Signal Voltage Gain	$V_O = \pm 3V$, $R_L = 500\Omega$	1.4		1.3		1.0		0.8		0.6		V/mV
		$V_O = \pm 3V$, $R_L = 100\Omega$	0.9		0.8		0.6		0.5		0.4		V/mV
V_{OUT}	Maximum Output Voltage Swing	$R_L = 500\Omega$, 30mV Overdrive	± 3.8		± 3.8		± 3.7		± 3.6		± 3.5		V
		$R_L = 100\Omega$, 30mV Overdrive	± 3.35		± 3.30		± 3.25		± 3.15		± 3.05		V
I_S	Supply Current	Per Amplifier	3.6		3.6		3.6		3.6		3.6		mA

TABLE 1: ELECTRICAL CHARACTERISTICS (Pre-Irradiation) $V_S = 5V$, $V_{CM} = 0V$, unless otherwise noted.

SYMBOL	PARAMETER	CONDITIONS	$T_A = 25^\circ\text{C}$			SUB-GROUP	$-55^\circ\text{C} \leq T_A \leq 125^\circ\text{C}$			SUB-GROUP	UNITS
			MIN	TYP	MAX		MIN	TYP	MAX		
V_{OS}	Input Offset Voltage	(Note 4)			2	1			5	2,3	mV
$\frac{\Delta V_{OS}}{\Delta \text{Temp}}$	Average Tempco of Offset Voltage	(Note 5)							30		$\mu\text{V}/^\circ\text{C}$
I_{OS}	Input Offset Current				400	1			1000	2,3	nA
I_B	Input Bias Current				± 4	1			± 10	2,3	μA
e_n	Input Noise Voltage Density	$f_0 = 10\text{kHz}$			8						$\text{nV}/\sqrt{\text{Hz}}$
i_n	Input Noise Current Density	$f_0 = 10\text{kHz}$			1						$\text{pA}/\sqrt{\text{Hz}}$
R_{IN}	Input Resistance	$V_{CM} = 1.5\text{V to } 3.5\text{V}$			3						$\text{M}\Omega$
A_{VOL}	Large-Signal Voltage Gain	$V_O = 1.5\text{V to } 3.5\text{V}$, $R_L \geq 500\Omega$			1	4		0.5		5,6	V/mV
		$V_O = 1.5\text{V to } 3.5\text{V}$, $R_L \geq 100\Omega$			0.7	4		0.3			V/mV
	Input Voltage Range (Positive)	Guaranteed by CMRR			3.5			3.5			V
	Input Voltage Range (Negative)	Guaranteed by CMRR				1.5			1.5		V
CMRR	Common-Mode Rejection Ratio	$V_{CM} = 1.5\text{V to } 3.5\text{V}$			73	1		68			dB
PSRR	Power Supply Rejection Ratio	$V_S = \pm 2\text{V to } \pm 5.5\text{V}$			78	1		72		2,3	dB
			Channel Separation	$V_{OUT} = 1.5\text{V to } 3.5\text{V}$, $R_L = 100\Omega$		81	1		77		
V_{OUT}	Output Voltage Swing (Positive)	$R_L = 500\Omega$, 30mV Overdrive			3.9	4		3.5		5,6	V
		$R_L = 100\Omega$, 30mV Overdrive			3.7	4		3.3		5,6	V
V_{OUT}	Output Voltage Swing (Negative)	$R_L = 500\Omega$, 30mV Overdrive				1.1			1.3		V
		$R_L = 100\Omega$, 30mV Overdrive				1.3			1.5	5,6	V
I_{OUT}	Maximum Output Current	$V_{OUT} = 1.5\text{V or } 3.5\text{V}$, 30mV Overdrive			± 25			± 15			mA
I_{SC}	Output Short-Circuit Current	$V_{OUT} = 2.5\text{V}$, 1V Overdrive (Note 3)			± 55			± 30			mA
I_S	Supply Current	Per Amplifier				4	1		7.5	2,3	mA

TABLE 2: ELECTRICAL CHARACTERISTICS (Post-Irradiation, Note 7) $V_S = 5V$, $V_{CM} = 0V$, $T_A = 25^\circ C$, unless otherwise noted.

SYMBOL	PARAMETER	CONDITIONS	10KRAD(Si)		20KRAD(Si)		50KRAD(Si)		100KRAD(Si)		200KRAD(Si)		UNITS
			MIN	MAX	MIN	MAX	MIN	MAX	MIN	MAX	MIN	MAX	
V_{OS}	Input Offset Voltage	(Note 4)	2.5		2.5		3		3.5		4.5		mV
I_{OS}	Input Offset Current		500		500		750		1000		1500		nA
I_B	Input Bias Current		± 5		± 5		± 7.5		± 10		± 15		μA
	Input Voltage Range (Negative) (Positive)	Guaranteed by CMRR	3.5	1.5	3.5	1.5	3.5	1.5	3.5	1.5	3.5	1.5	V V
CMRR	Common-Mode Rejection Ratio	$V_{CM} = 1.5V$ to $3.5V$	71		71		69		66		63		dB
PSRR	Power Supply Rejection Ratio	$V_S = \pm 2V$ to $\pm 5.5V$	77		75		72		70		68		dB
A_{VOL}	Large-Signal Voltage Gain	$V_O = 1.5V$ to $3.5V$, $R_L = 500\Omega$	0.9		0.8		0.6		0.5		0.4		V/mV
		$V_O = 1.5V$ to $3.5V$, $R_L = 100\Omega$	0.6		0.55		0.45		0.40		0.35		V/mV
V_{OUT}	Maximum Output Voltage Swing (Positive)	$R_L = 500\Omega$, 30mV Overdrive	3.9		3.9		3.8		3.7		3.6		V
		$R_L = 100\Omega$, 30mV Overdrive	3.7		3.65		3.55		3.45		3.40		V
V_{OUT}	Maximum Output Voltage Swing (Negative)	$R_L = 500\Omega$, 30mV Overdrive	1.1		1.1		1.15		1.2		1.3		V
		$R_L = 100\Omega$, 30mV Overdrive	1.3		1.35		1.4		1.45		1.5		V
I_S	Supply Current	Per Amplifier	4		4		4		4		4		mA

Note 1: Absolute Maximum Ratings are those values beyond which the life of the device may be impaired.

Note 2: Differential inputs of $\pm 6V$ are appropriate for transient operation only, such as during slewing. Large sustained differential inputs can cause excessive power dissipation and may damage the part.

Note 3: A heat sink may be required to keep the junction temperature below absolute maximum when the output is shorted indefinitely.

Note 4: Input offset voltage is pulse tested and is exclusive of warm-up drift.

Note 5: This parameter is not 100% tested.

TABLE 2: ELECTRICAL TEST REQUIREMENTS

MIL-STD-883 TEST REQUIREMENTS	SUBGROUP
Final Electrical Test Requirements (Method 5004)	1*,2,3,4,5,6
Group A Test Requirements (Method 5005)	1,2,3,4,5,6
Group B and D for Class S End Point Electrical Parameters (Method 5005)	1,2,3

* PDA applies to subgroup 1. See PDA Test Notes.

PDA Test Notes

The PDA is specified as 5% based on failures from group A, subgroup 1, tests after cooldown as the final electrical test in accordance with method 5004 of MIL-STD-883. The verified failures of group A, subgroup 1, after burn-in divided by the total number of devices submitted for burn-in in that lot shall be used to determine the percent for the lot.

Linear Technology Corporation reserves the right to test to tighter limits than those given.

TOTAL DOSE BIAS CIRCUIT

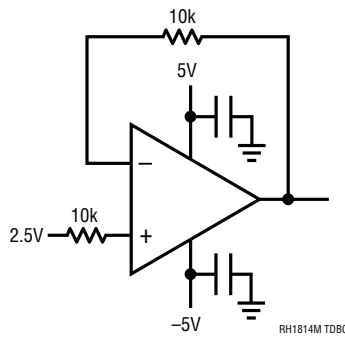

TYPICAL PERFORMANCE CHARACTERISTICS

Supply Current (Per Amplifier)

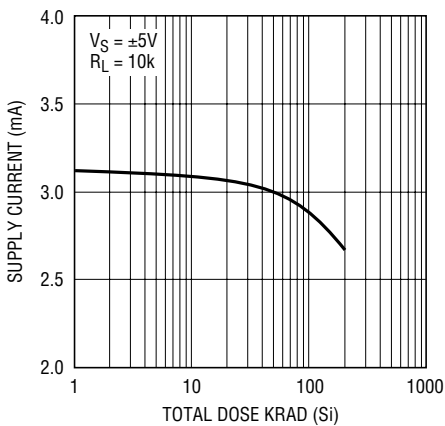

RH1814M G01

Positive Slew Rate

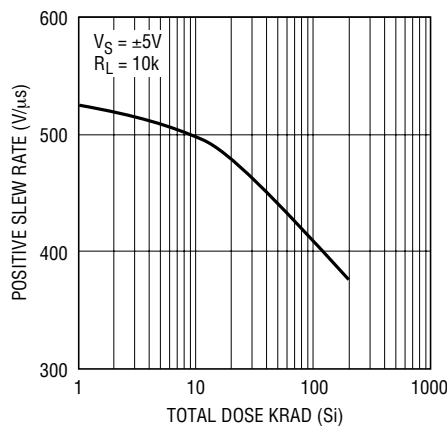

RH1814M G02

Negative Slew Rate

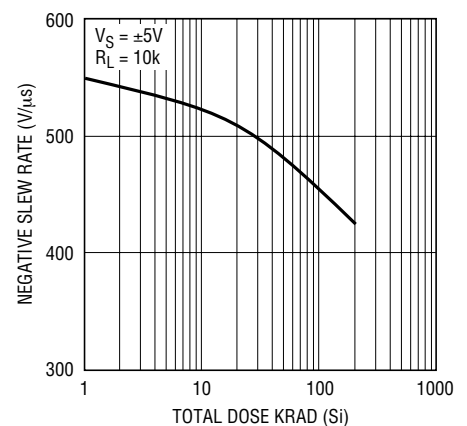

RH1814M G03

TYPICAL PERFORMANCE CHARACTERISTICS

Input Offset Voltage

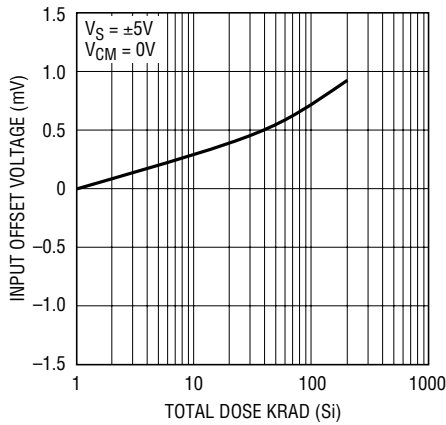

RH1814M G04

Input Bias Current

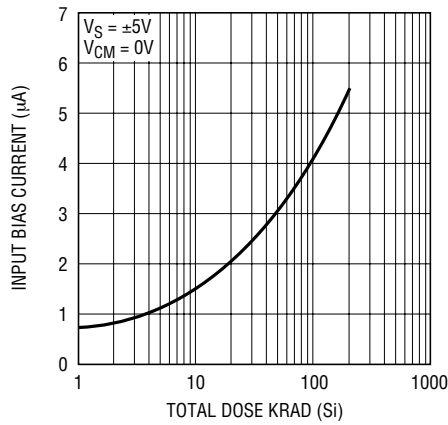

RH1814M G05

Input Offset Current

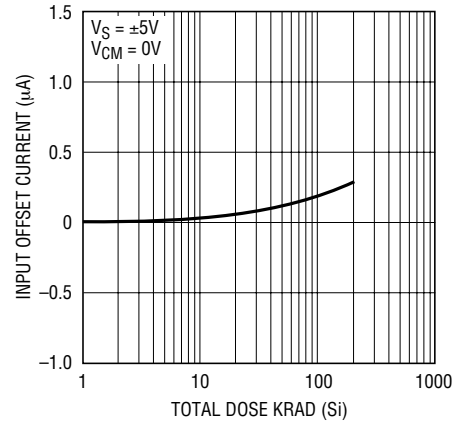

RH1814M G06

Open-Loop Gain

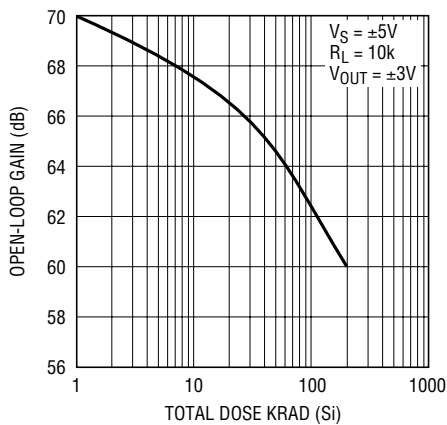

RH1814M G07

Common-Mode Rejection Ratio

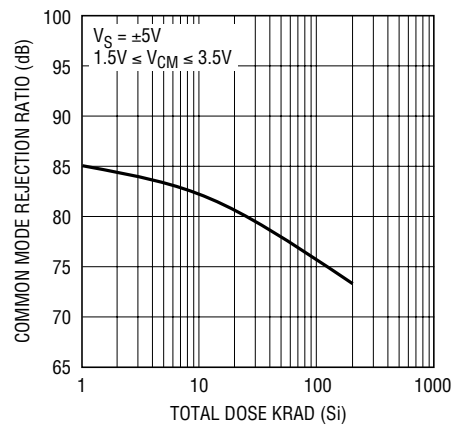

RH1814M G08

Power Supply Rejection Ratio

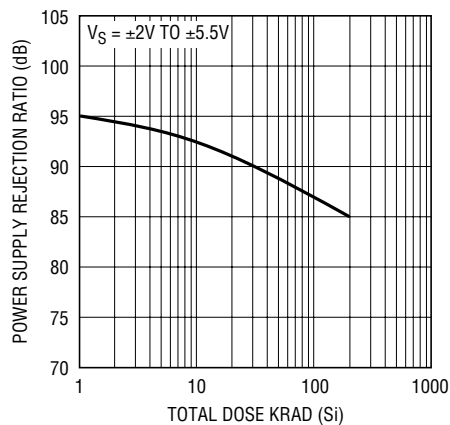

RH1814M G09

Gain Bandwidth Product

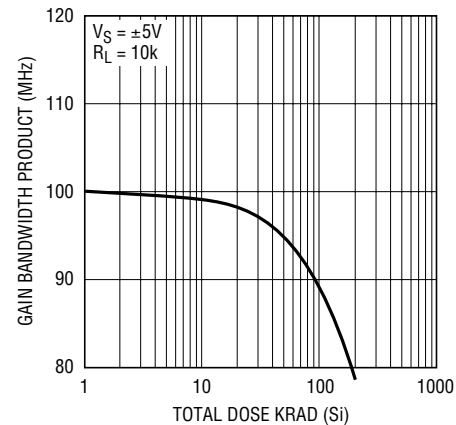

RH1814M G11

RH1814M

I.D. No. 66-11-1814 1104



Linear Technology Corporation
1630 McCarthy Blvd., Milpitas, CA 95035-7417
(408) 432-1900 • FAX: (408) 434-0507 • www.linear.com

LT/LT 1104 • PRINTED IN USA

 **LINEAR**
TECHNOLOGY
©LINEAR TECHNOLOGY CORPORATION 2004